

Figure 1 PDA Block Diagram
Edit 82 for layout 13a

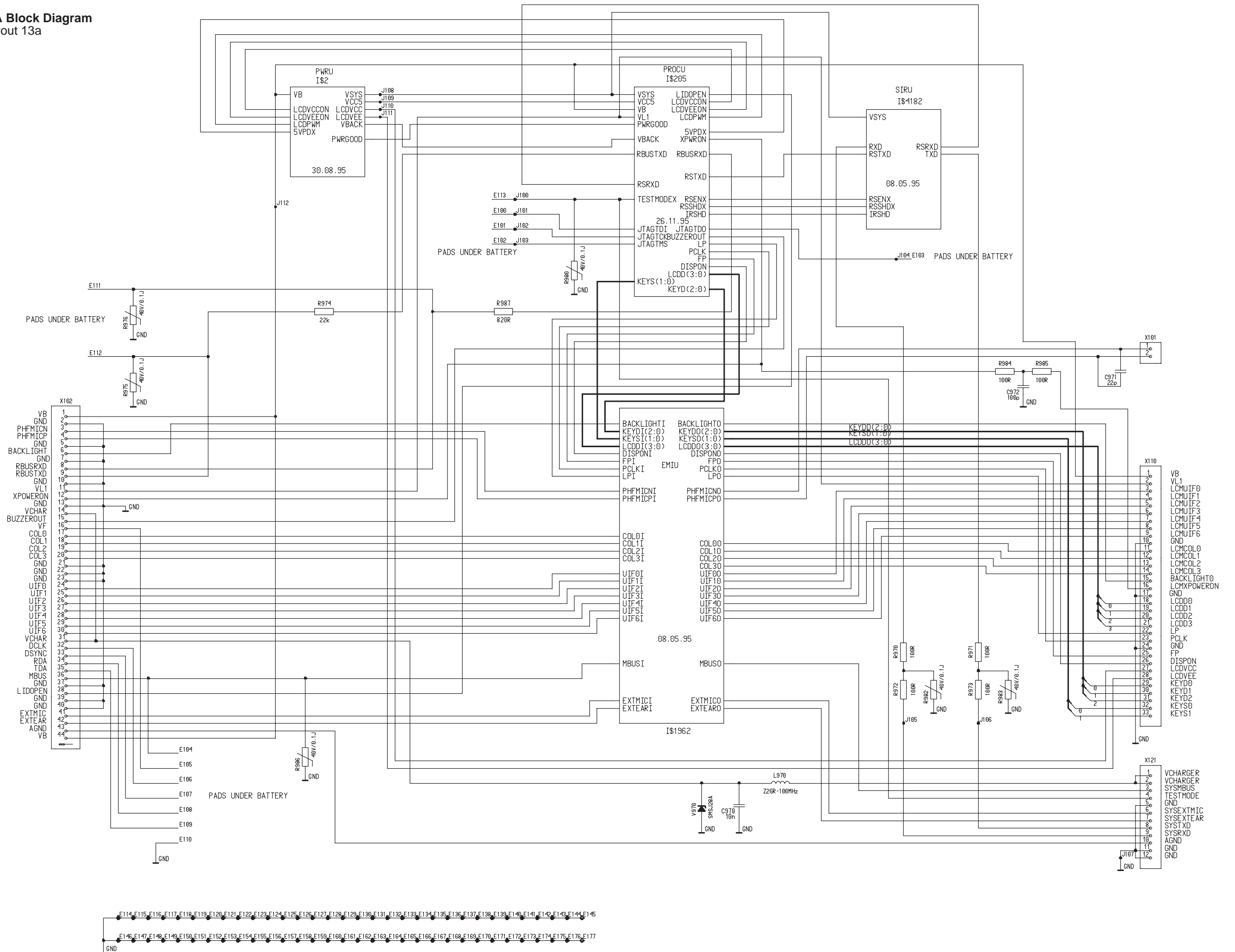

Figure 2 PDA Power Unit -PWRU
Edit 108 for layout 13a

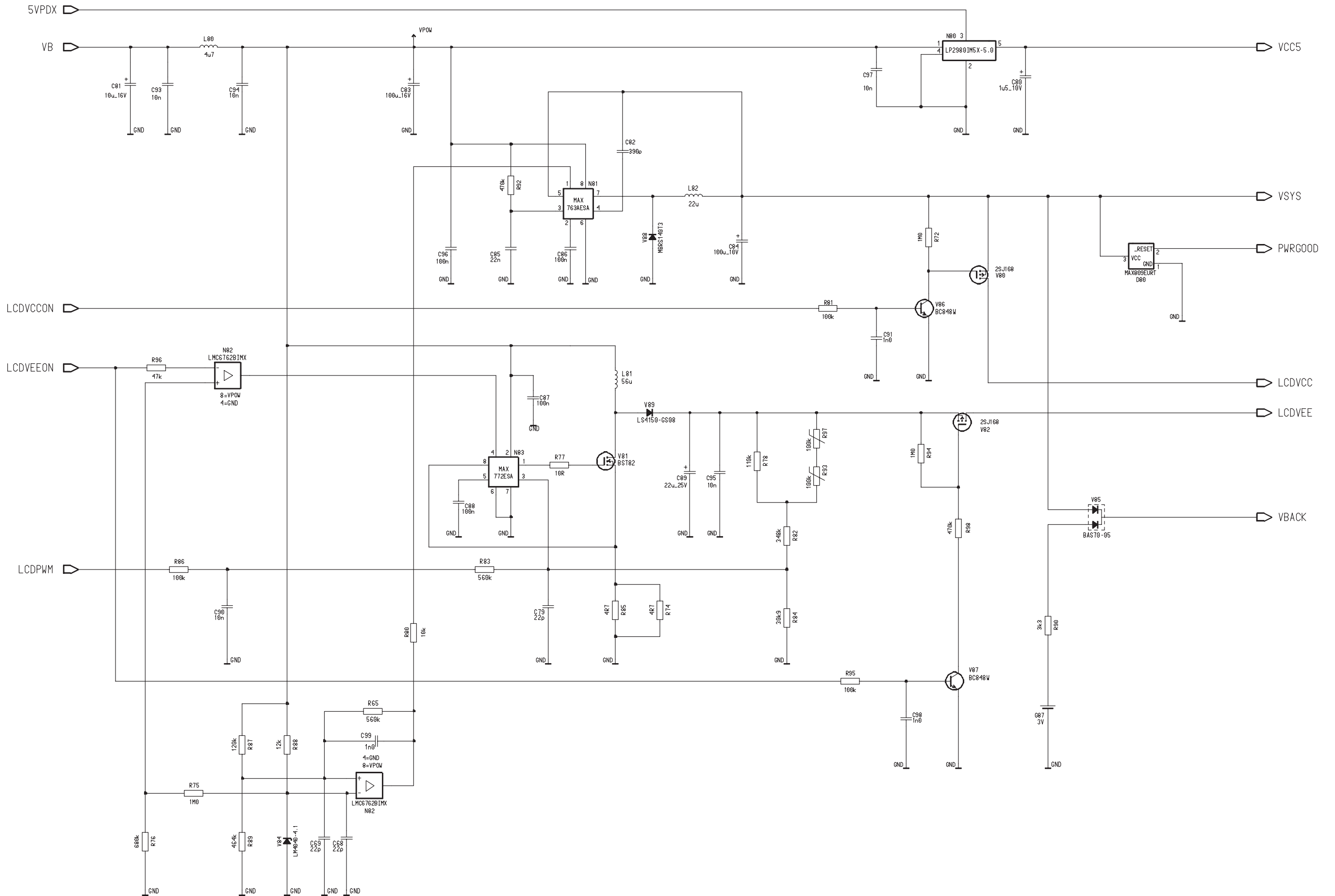

Figure 3 PDA Serial Interface – SIRU
 Edit 24 for layout 13a

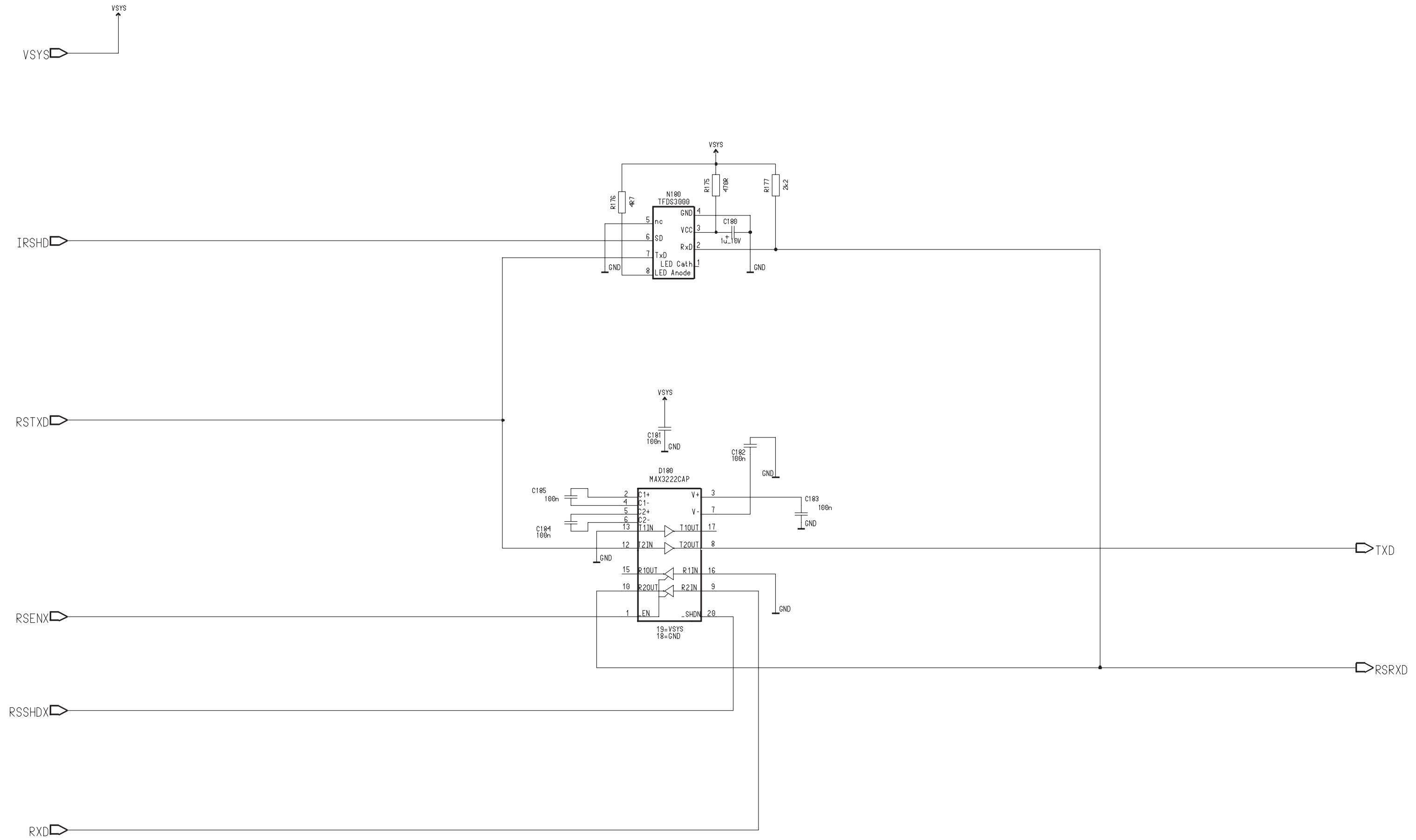

Figure 4 PDA MCU and Memory – PROCU
Edit 121 for layout 13a

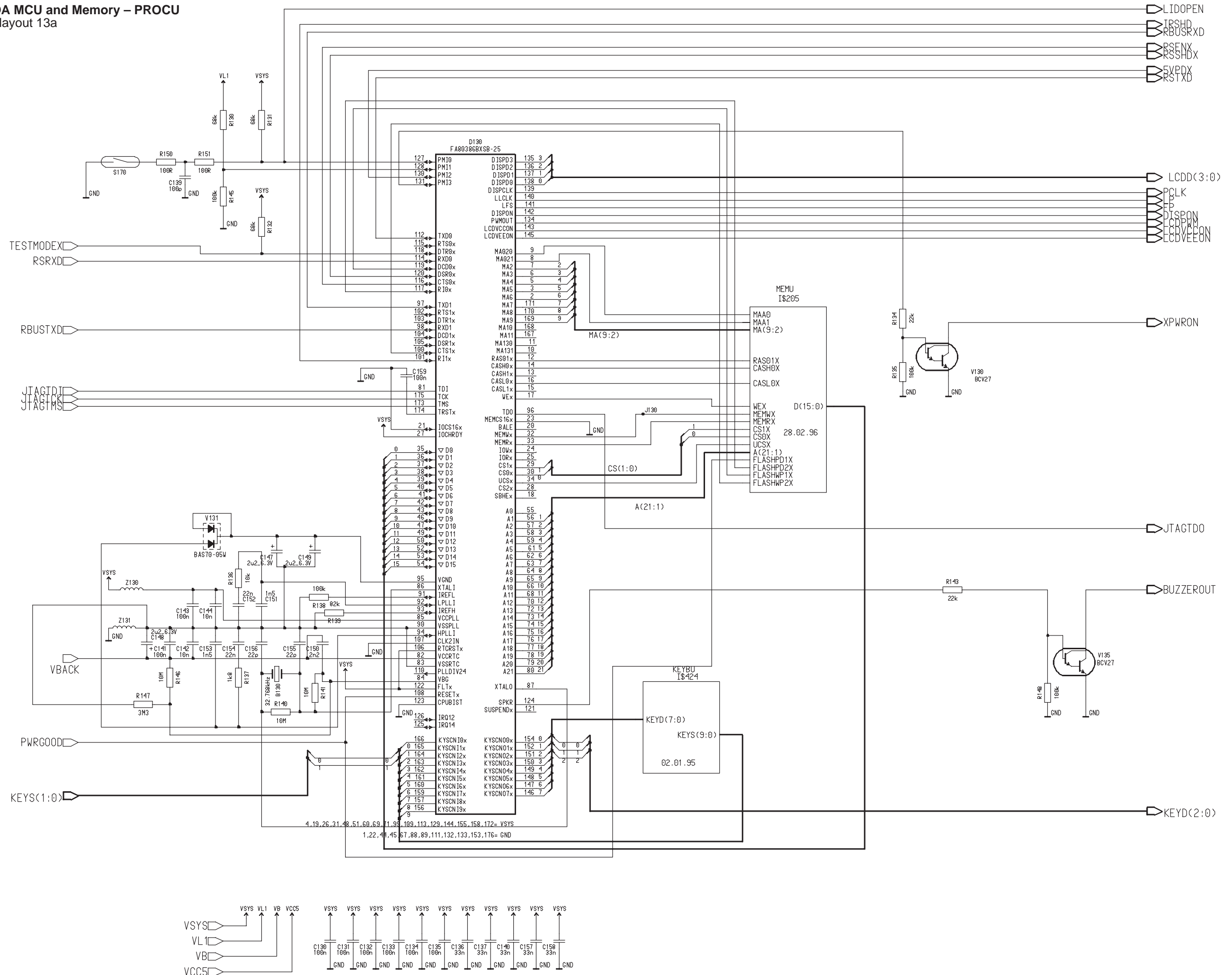

Figure 5 PDA EMIU
Edit 21 for layout 13a

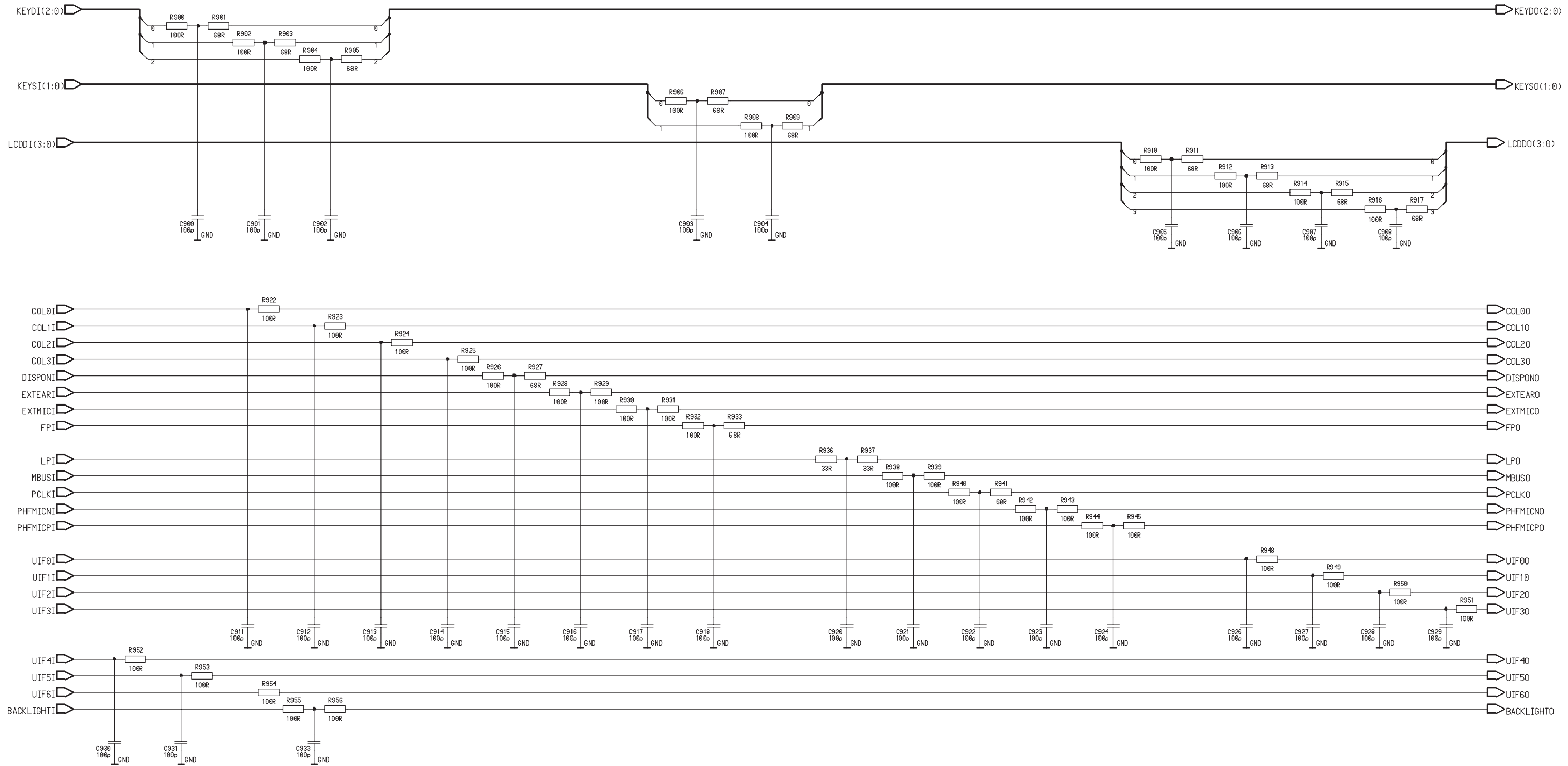

Figure 6 Keyboard matrix
Edit 24 for layout 13a

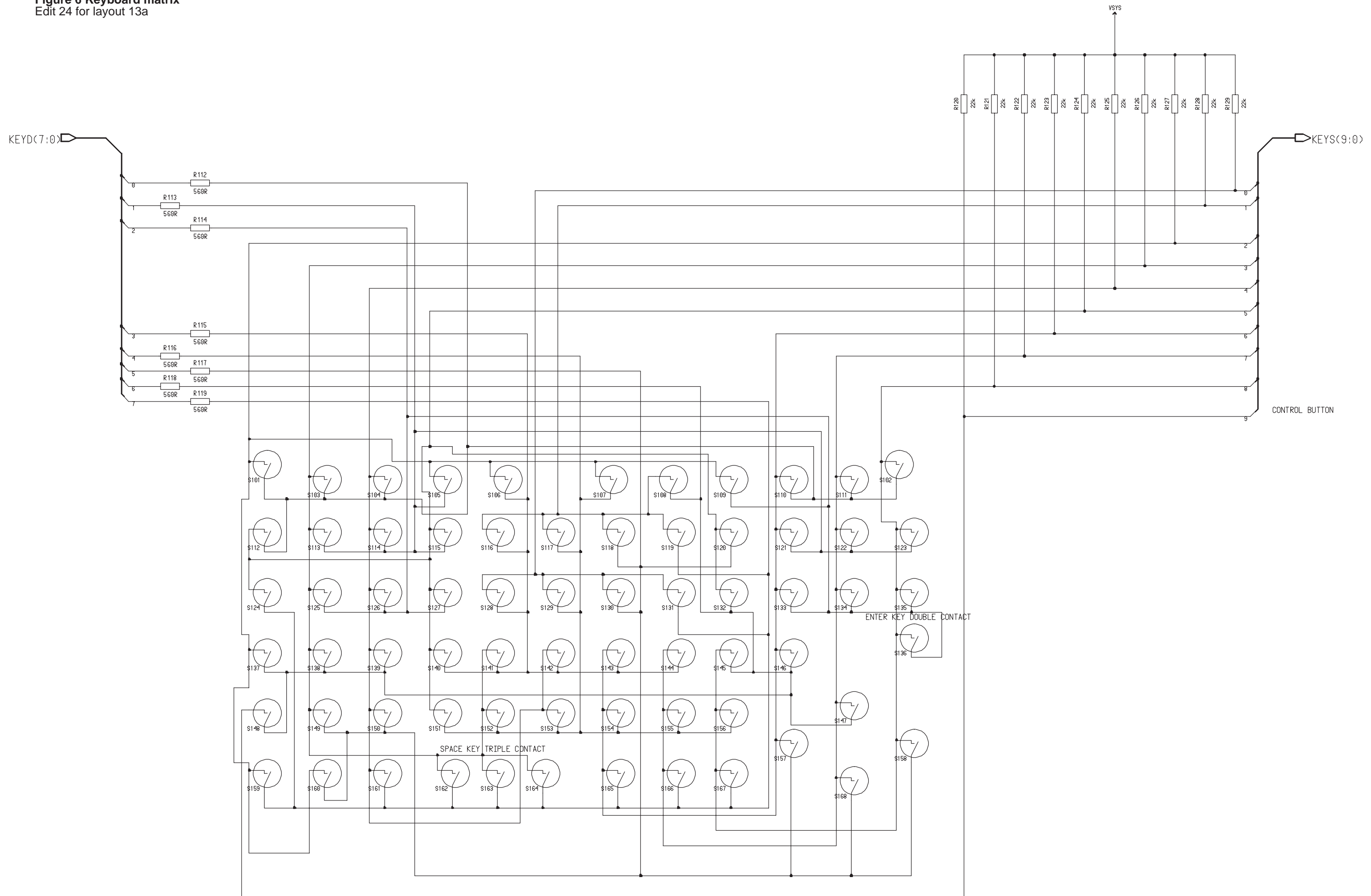

Figure 7 PDA Memory
Edit 28 for layout 13a

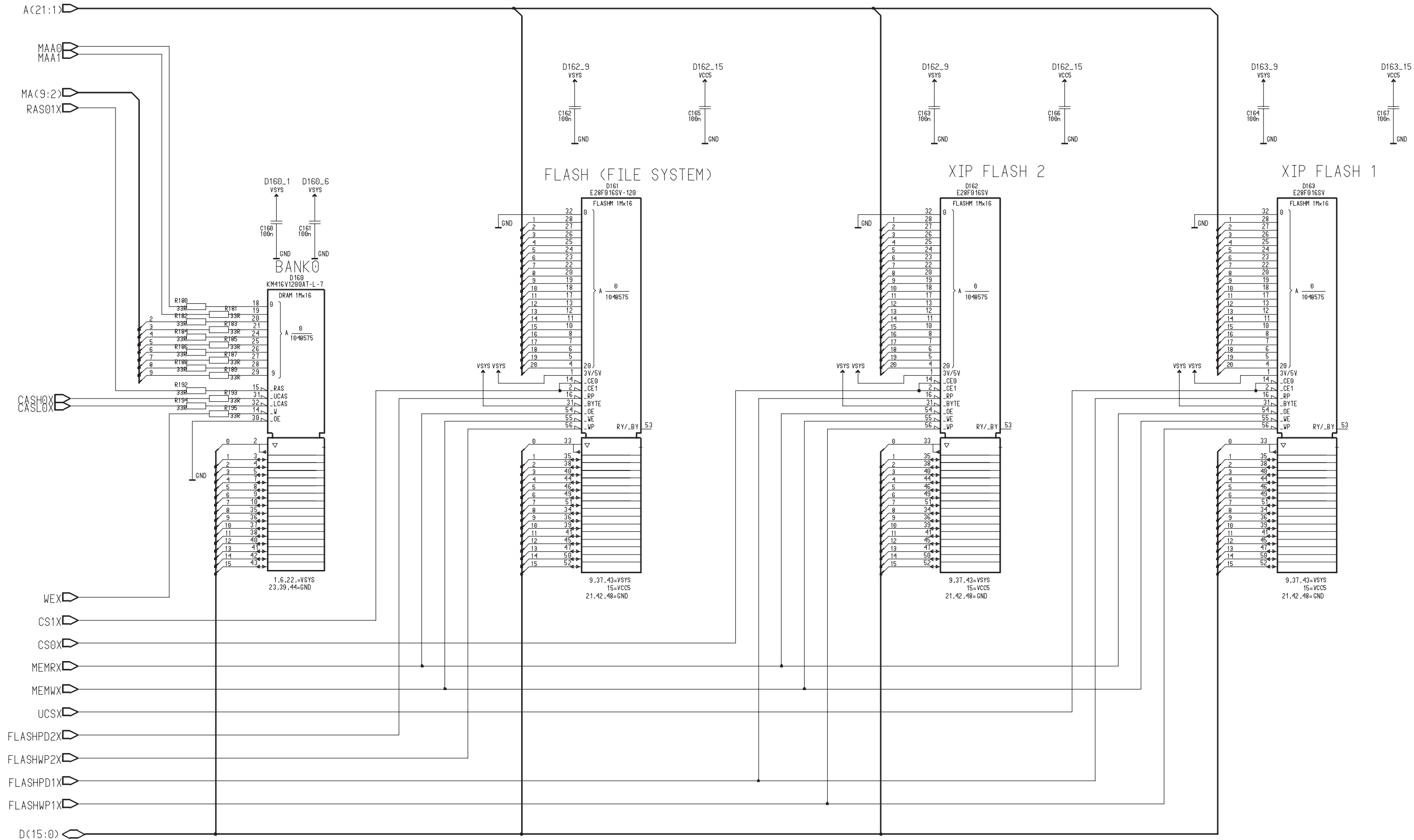

Figure 8 PDA Component Layout 13a

